



SMT

Soil Management Tool



Service Parts Manual & Parts Price Guide

Models SMT101, SMT151, SMT203, and SMT303

Serial Number 314256 to Current



HCC, inc
1501 1st Avenue
(815) 539-9371
www.smart-till.com

C-1184
January 2014

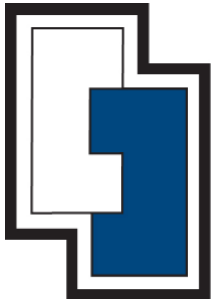

HCC, inc.®



**1501 1st Avenue
Mendota, IL 61342**

Ordering - Payment

HCC, inc. business hours are 7:30 AM - 4:30 PM (CST), Monday through Friday

Orders may be placed by phone, fax, mail, e-mail or contact HCC, inc online at www.smart-till.com

Phone: (815) 539-9371

Fax: (815) 539-3135

Email: ctowne@hccinc.com

1501 1st Ave
Mendota, IL 61342

MINIMUM ORDER \$50

Shipping

All shipments are F.O.B factory location

Returns - Shortages - Claims

If not completely satisfied, return parts within 30 days of delivery for a full refund. All merchandise returned must have proper authorization from HCC, inc. A 20% restocking fee will be made on all returns for reasons other than shipping error or warranty. Returns must be in good condition (excluding warranty returns.) There are no returns on special order items.

Please check merchandise immediately upon receipt and report any error at once. If a part of the shipment is missing or received in bad condition, you must note this fact on the carrier's receipt and make a claim with the carrier immediately. **Consignee is responsible for the damaged freight** if the bill of lading is signed upon delivery. Be certain to sign for the correct number of cartons.

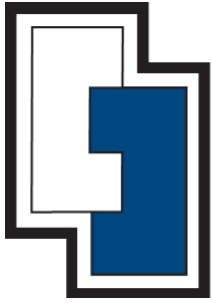

HCC, inc.[®]

**1501 1st Avenue
Mendota, IL 61342**

Limited Warranty

HCC, inc. warrants each new HCC, inc. product to be free from defects in material and workmanship. This warranty is applicable only for the normal service life expectancy of the product or components, not to exceed 12 consecutive months from the date of delivery of the new HCC, inc. product to the original purchaser.

Genuine HCC, inc. replacement parts and components will be warranted for 90 days from date of purchase, or the remainder of the original equipment warranty period, whichever is longer. There is no warranty for tines.

Under no circumstances will it cover any merchandise or components thereof, which, in the opinion of the company, has been subjected to misuse, unauthorized modifications, alternation, an accident, or if repairs have been made with parts other than those obtainable through HCC, inc.

Our obligation under this warranty shall be limited to repairing or replacing, free of charge to the original purchaser, any part that, in our judgment, shall show evidence of such defect, provided further that such part shall be returned within (30) days from date of failure to HCC, inc., routed through the dealer and distributor from whom the purchase was made, transportation charges prepaid.

This warranty shall not be interpreted to render HCC, inc. liable for injury or damages of any kind or nature to person or property. This warranty does not extend to the loss of crops, loss because of delay in harvesting, or any expense or loss incurred for labor, substitute machinery, rental, or for any other reason.

Except as set forth above, **HCC, inc. shall have no obligation or liability of any kind on account of any of its equipment and shall not be liable for special or consequential damages. HCC, inc. makes no other warranty, expressed or implied, and specifically, HCC, inc. disclaims any implied warranty of merchantability or fitness for a particular purpose. Some states or provinces do not permit limitations or exclusions of implied warranties or incidental or consequential damages, so the limitations or exclusion in this warranty may not apply.**

This Warranty is subject to any existing condition of supply which may directly affect our ability to obtain materials or manufacture replacement parts.

HCC, inc. reserves the right to make improvements in design or changes in specifications at any time, without incurring any obligation to owners of units previously sold.

No one is authorized to alter, modify, or enlarge this warranty nor the exclusion, limitations, and reservations. **Effective with products delivered to original user on or after January 1, 2006.**

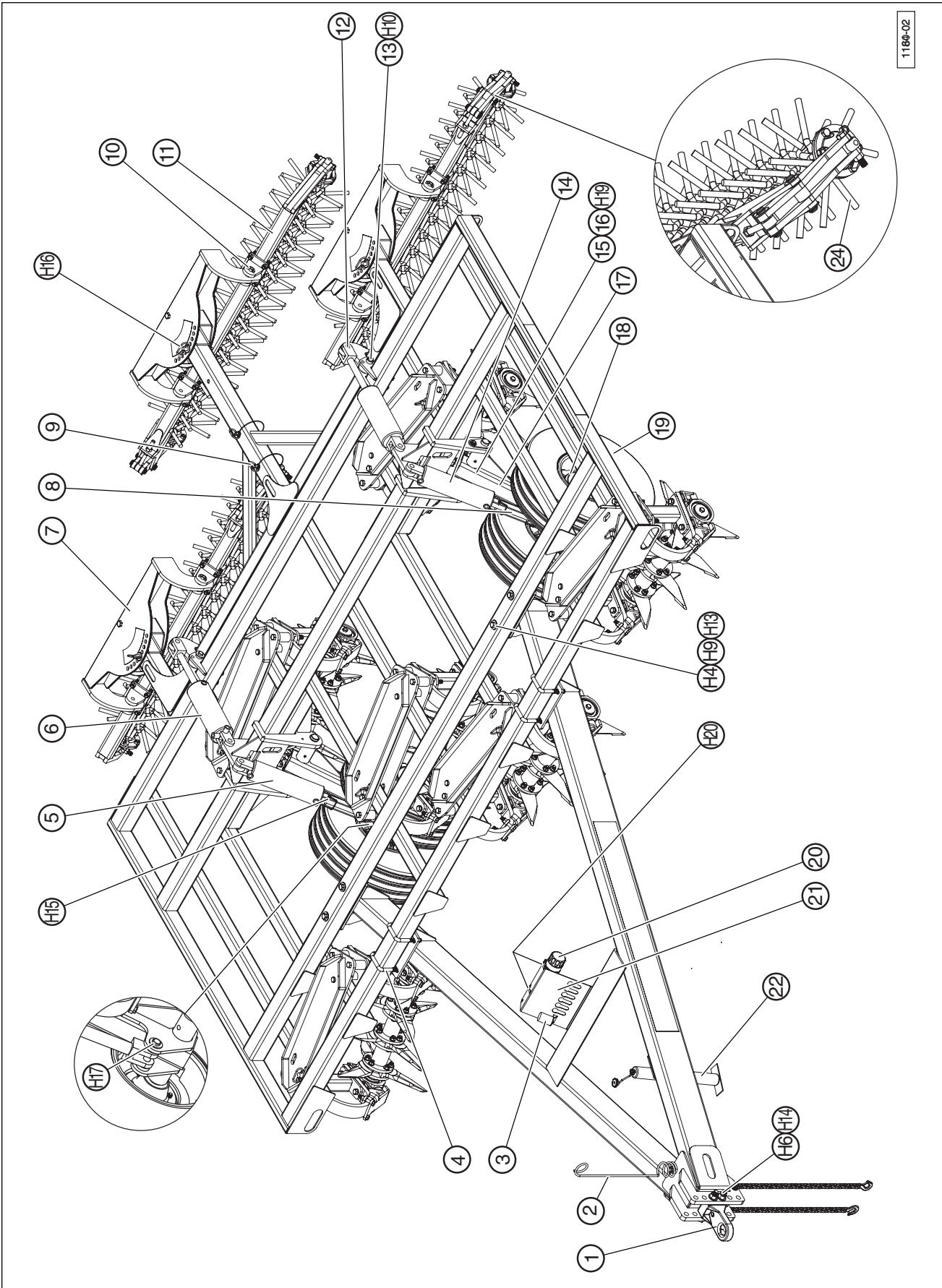

1184-02

SMT151 Smart-Till® Shown - SMT101 Similar (NOTE: Parts identified with an "H" prefix are hardware items listed on page 14)

SMT101 and SMT151 Smart-Till® Parts List

Item No.	Part Number	Description	SMT101 Qty.	SMT151 Qty.	Jan. 2014 List Price*
1	231272	Implement Hitch (tongue)	1	1	\$ 138.83
2	226333	Wiring Harness Guide (tongue)	1	1	\$ 22.98
3	235228	Wiring Harness Plug Holder (tongue)	1	1	\$ 12.92
4	202934	Square Bend U-Bolt	4	4	\$ 28.98
5	263557	Hydraulic Cylinder, Right-Hand, 3.50" Bore (wheel lift)	1	1	\$ 309.78
6	263551	Hydraulic Cylinder, 3.50" bore (rotary harrow attachment)	2	2	\$ 255.71
7	853067	Harrow Weldment (adjustment)	2	3	\$ 606.63
8	553090	Transport Lock (transport wheel hydraulic cylinder)	2	2	\$ 19.40
9	216182	Hitch Pin, 0.625" diameter (transport lock)	2	2	\$ 15.24
10	243757	Bushing, 0.750" I.D. (rotary harrow bracket)	4	6	\$ 14.00
11	853033	Rotary Harrow Module with Brackets (6' length)	2	3	\$ 2,237.01
12	216174	Pin, 1.00" diameter x 2.75" long (hydraulic cylinder)	6	6	\$ 12.44
13	216177	Pin, 1.00" diameter x 5" long (rotary harrow pivot bracket)	2	2	\$ 13.29
14	263556	Hydraulic Cylinder, Left-Hand, 3.75" Bore (wheel lift)	1	1	\$ 343.76
15	243756	Bronze Bushing 1.75" I.D. (transport wheel pivot)	4	4	\$ 19.43
16	853017	Axle Pivot Pin, 1.75" diameter x 16" long (transport wheel)	2	2	\$ 121.87
17	853068	Axle Arm Weldment (tandem wheel)	2	2	\$ 958.13
18	226334	Heavy Duty Spindle and Hub Assembly (transport wheel)	4	4	\$ 127.37
19	853013	Ag Tire and Wheel Assembly	4	4	\$ 385.12
20	275254	Document Storage Tube (tongue)	1	1	\$ 34.53
21	553087	Hose End Storage Plate (tongue)	1	1	\$ 39.50
22	226332	Tongue Jack	1	1	\$ 169.69
23	853046	Clevis Assembly (optional, not shown)	1	1	\$ 77.00
24	231292	Harrow Module Tine (6' length)	180	270	\$ 9.31
25	853141	Base Shipping Stand (not shown)	4	4	\$ 59.67

NOTE: In the illustration above, parts identified with an "H" prefix are hardware items listed on page 14

* Per each list price

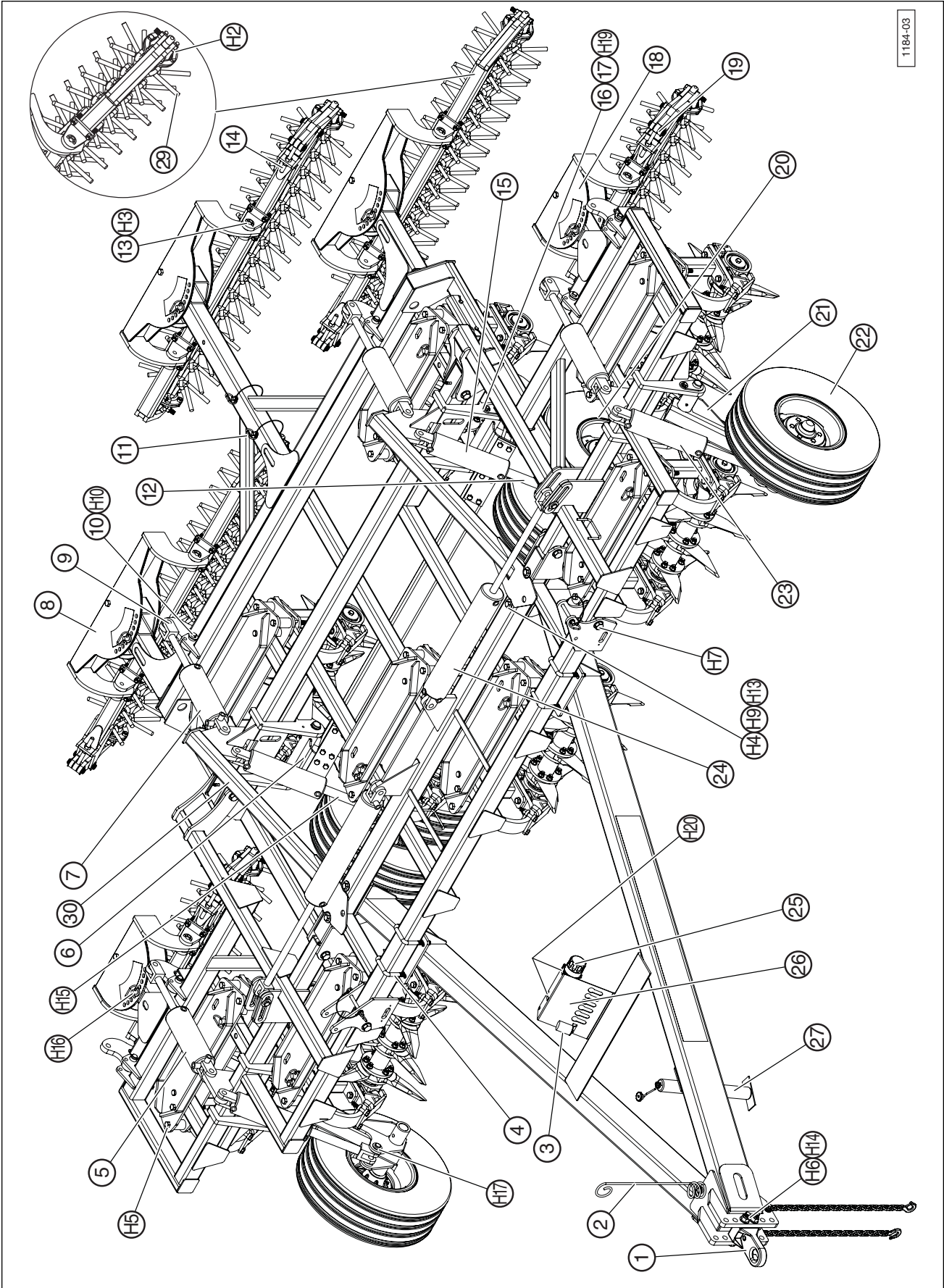

1184-03

SMT203 Smart-Till® (NOTE: Parts identified with an "H" prefix are hardware items listed on page 14)

SMT203 Smart-Till® Parts List

Item No.	Part Number	Description	SMT203 Qty.	Jan. 2014 List Price*
1	231272	Implement Hitch (tongue)	1	\$ 138.83
2	226333	Wiring Harness Guide (tongue)	1	\$ 22.98
3	235228	Wiring Harness Plug Holder (tongue)	1	\$ 12.92
4	202934	Square Bend U-Bolt	4	\$ 28.98
5	263558	Hydraulic Cylinder, 3.75" Bore (rotary harrow attachment)	2	\$ 306.22
6	853012	Axle Arm Weldment (tandem wheel)	2	\$ 964.13
7	263559	Hydraulic Cylinder, 3.50" bore (rotary harrow attachment)	2	\$ 276.24
8	853067	Harrow Weldment (adjustment)	3	\$ 606.63
9	216174	Pin, 1.00" diameter x 2.75" long (hydraulic cylinder)	16	\$ 12.44
10	216177	Pin, 1.00" diameter x 5" long (rotary harrow pivot bracket)	6	\$ 13.29
11	216182	Hitch Pin, 0.625" diameter (transport lock)	2	\$ 15.24
12	553090	Transport Lock (transport wheel hydraulic cylinder)	2	\$ 19.40
13	243757	Bushing, 0.750" I.D. (rotary harrow bracket)	10	\$ 14.00
14	853033	Rotary Harrow Module with Brackets (6' length)	3	\$ 2,237.01
15	263557	Hydraulic Cylinder, 3.50" Bore (tandem wheel lift)	2	\$ 309.78
16	243756	Bronze Bushing 1.75" I.D. (transport wheel pivot)	4	\$ 19.43
17	853017	Axle Pivot Pin, 1.75" diameter x 16" long (transport wheel)	4	\$ 121.87
18	853065	Small Harrow Weldment (adjustment)	2	\$ 292.94
19	853044	Rotary Harrow Module with Brackets (3' length)	2	\$ 1,753.11
20	226334	Heavy Duty Spindle and Hub Assembly (transport wheel)	6	\$ 127.37
21	853068	Axle Arm Weldment (single wheel)	2	\$ 958.13
22	853013	Ag Tire and Wheel Assembly	6	\$ 385.12
23	263556	Hydraulic Cylinder, 3.75" Bore (single wheel lift)	2	\$ 343.76
24	263560	Hydraulic Cylinder, 3.50" Bore (side wing lift)	2	\$ 374.71
25	275254	Document Storage Tube (tongue)	1	\$ 34.53
26	553087	Hose End Storage Plate (tongue)	1	\$ 39.50
27	226332	Tongue Jack	1	\$ 169.69
28	853046	Clevis Assembly (optional, not shown)	1	\$ 77.00
29	231292	Harrow Module Tine (3' length)	144	\$ 9.31
29	231292	Harrow Module Tine (6' length)	180	\$ 9.31
30	853128	Kit - 20' Main Frame Reinforcement	2	\$ 455.21
31	853141	Base Shipping Stand (not shown)	6	\$ 59.67

NOTE: In the illustration above, parts identified with an "H" prefix are hardware items listed on page 14

* Per each list price

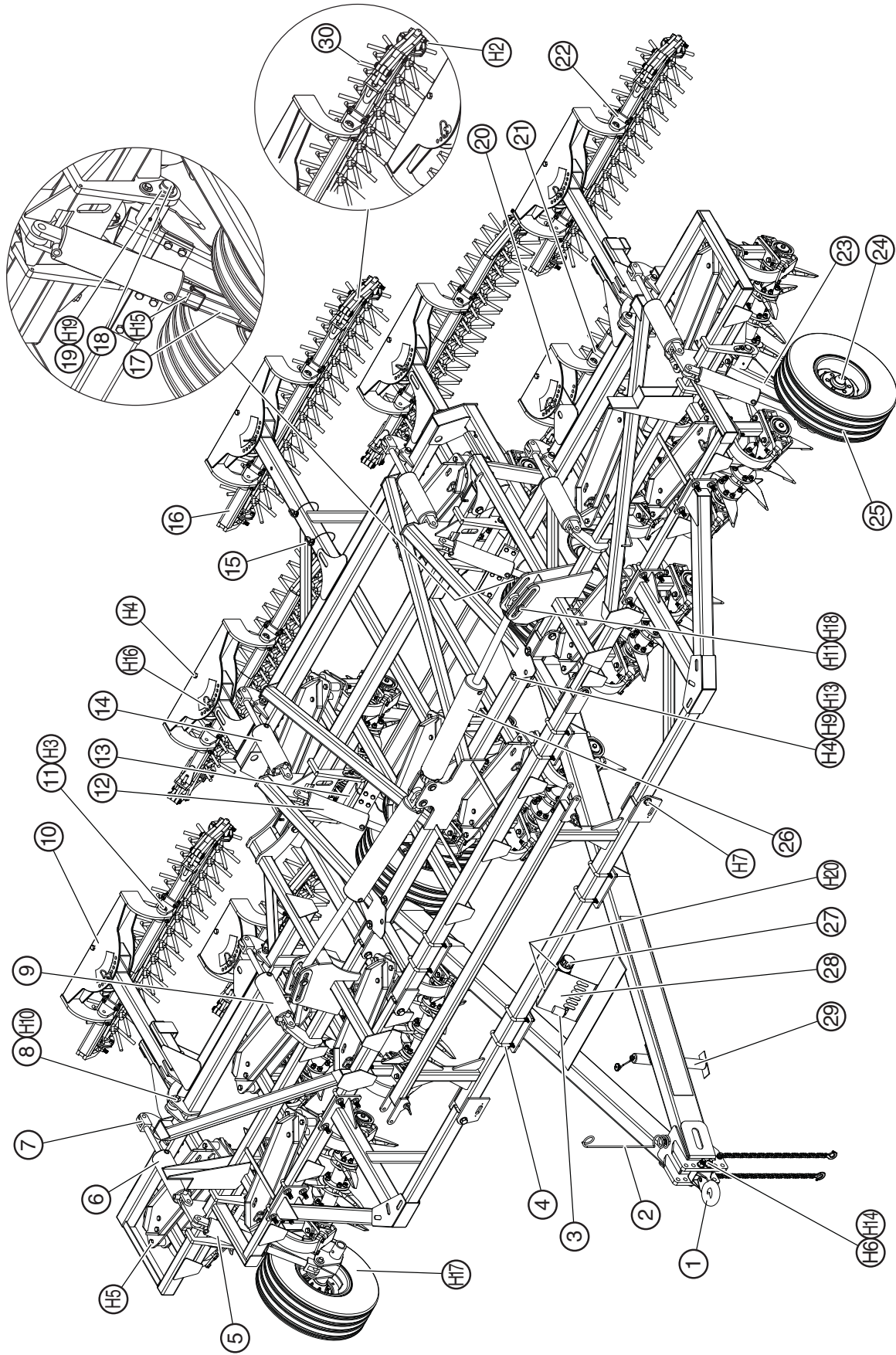

SMT303 Smart-Till® (NOTE: Parts identified with an "H" prefix are hardware items listed on page 14)

SMT303 Smart-Till® Parts List

Item No.	Part Number	Description	SMT303 Qty.	Jan. 2014 List Price*
1	231274	Heavy Duty Implement Hitch (tongue)	1	\$ 187.80
2	226333	Wiring Harness Guide (tongue)	1	\$ 22.98
3	235228	Wiring Harness Plug Holder (tongue)	1	\$ 12.92
4	202934	Square Bend U-Bolt	16	\$ 28.98
5	263556	Hydraulic Cylinder, 3.75" Bore (wheel lift)	2	\$ 343.76
6	263558	Hydraulic Cylinder, 3.75" Bore (rotary harrow attachment)	2	\$ 306.22
7	216174	Pin, 1.00" diameter x 2.75" long (hydraulic cylinder)	18	\$ 12.44
8	216177	Pin, 1.00" diameter x 5" long (rotary harrow pivot bracket)	8	\$ 13.29
9	263551	Hydraulic Cylinder, 3.50" Bore (rotary harrow attachment)	2	\$ 255.71
10	853067	Harrow Weldment (adjustment)	5	\$ 606.63
11	243757	Bushing, 0.750" I.D. (rotary harrow bracket)	14	\$ 14.00
12	263557	Hydraulic Cylinder, 3.50" Bore (wheel lift)	2	\$ 309.78
13	853012	Axle Arm Weldment (tandem wheel)	2	\$ 964.13
14	263559	Hydraulic Cylinder, 3.50 Bore (rotary harrow attachment)	2	\$ 276.24
15	216182	Hitch Pin, 0.625" diameter (transport lock)	2	\$ 15.24
16	853033	Rotary Harrow Module with Brackets (6' length)	1	\$ 2,237.01
17	553090	Transport Lock (transport wheel hydraulic cylinder)	2	\$ 19.40
18	853017	Axle Pivot Pin, 1.75" diameter x 16" long (transport wheel)	4	\$ 121.87
19	243756	Bronze Bushing 1.75" I.D. (transport wheel pivot)	8	\$ 19.43
20	853065	Small Harrow Weldment (adjustment)	2	\$ 292.94
21	853044	Rotary Harrow with Brackets (3' length)	2	\$ 1,753.11
22	853066	Rotary Harrow with Brackets (5' 7" length)	4	\$ 2,153.75
23	853068	Axle Arm Weldment (single wheel)	2	\$ 958.13
24	226334	Heavy Duty Spindle and Hub Assembly	6	\$ 127.37
25	853013	Ag Tire and Wheel Assembly	6	\$ 385.12
26	263562	Hydraulic Cylinder, 5.0" Bore (side wing lift)	2	\$ 753.75
27	275254	Document Storage Tube (tongue)	1	\$ 34.53
28	553087	Hose End Storage Plate (tongue)	1	\$ 39.50
29	226332	Tongue Jack (included mounting metal plate)	1	\$ 169.69
30	231292	Harrow Module Tine (3' length)	96	\$ 9.31
30	231292	Harrow Module Tine (5' 7" length)	336	\$ 9.31
30	231292	Harrow Module Tine (6' length)	90	\$ 9.31
31	853141	Base Shipping Stand (not shown)	6	\$ 59.67

NOTE: In the illustration above, parts identified with an "H" prefix are hardware items listed on page 14

* Per each list price

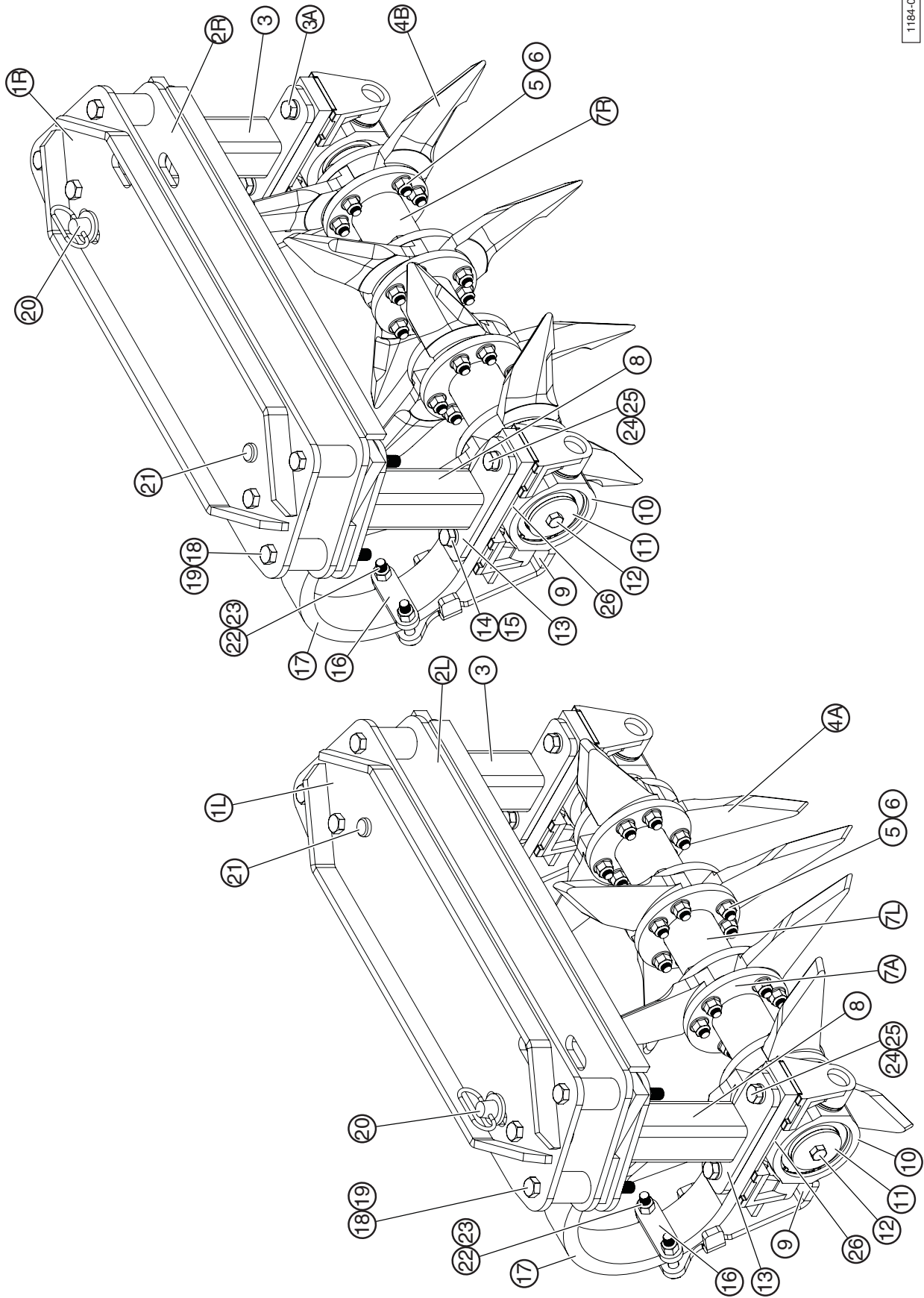

Smart-Till® Left-Hand and Right-Hand Carriage/Tine Gang

Smart-Till® Carriage/Tine Gang Parts List

Item No.	Part Number	Description	Qty.	Jan. 2014 List Price*
1L	853064	Left-Hand Upper Carriage Plate Weldment	1	\$ 180.55
2L	853145	Left-Hand Lower Carriage Plate Weldment (SMT)	1	\$ 257.16
1R	853057	Right-Hand Upper Carriage Plate Weldment	1	\$ 180.55
2R	853146	Right-Hand Lower Carriage Plate Weldment (SMT)	1	\$ 257.16
3	853061	Right-Hand Tube Stop Weldment	1	\$ 69.60
4A	231250**	Aerator Tine - Casting Mark RR/LF	12	\$ 25.45
4B	231251**	Aerator Tine - Casting Mark LR/RF	12	\$ 25.45
5	202925**	Bolt, 5/8-18 UNF x 3-1/2" long - Grade 8	24	\$ 2.67
6	212500**	Top Lock Flange Nut - 5/8-18 UNF	24	\$ 1.16
7L	853148	Left-Hand Roller Weldment (w/o tines) (SMT)	1	\$ 662.80
7R	853147	Right-Hand Roller Weldment (w/o tines) (SMT)	1	\$ 662.80
7A	553021	Floating Ring (1 additional ring is needed when ordering 7L or 7R)	1	\$ 18.53
8	853060	Left-Hand Tube Stop Weldment	1	\$ 69.63
9	853152***	Rock Guard Weldment Trunnion (SMT)	2	\$ 48.10
10	553389	Trunnion Bearing Assembly (SMT) Includes the following (not sold separately): 231300 Trunnion Hanger (4) 553405 Thrust Washer (4) 231302 Trunnion Bearing (2)	2	\$ 173.53
11	553390	Thrust Plate Roller (SMT)	2	\$ 7.53
12	202270	Bolt, Hex Head Machine Screw - 5/8-11 x 1.50	2	\$ 0.80
13	853010	C-Flex Pin Stop	2	\$ 32.27
16	553239***	Plate Guard Retainer	2	\$ 8.00
17	553237	C-Flex - 1 x 3" wide (3-hole)	2	\$ 87.25
18	202929	Bolt, 3/4-10 UNC x 7-1/2" long - Grade 8	6	\$ 8.40
19	212503	Lock Nut Nylon Insert - 3/4-10 UNC - Grade 8	6	\$ 0.98
20	216179	Hitch Pin - 1 x 4-1/2" long w/hairpin clip	1	\$ 25.33
21	216178	Pivot Pin - 1 x 4-1/2" long w/hairpin clip	1	\$ 10.89
22	202440***	Bolt, Hex Head - 5/8-11 UNC x 2.75" (SMT)	4	\$ 1.96
23	212167***	Center Lock Nut 5/8-11 UNC	4	\$ 1.11
24	212508	Bolt, M18-2.5 x 70mm long - Grade 8 (SMT)	4	\$ 3.24
25	214390	Washer, Lock 3/4" (SMT)	4	\$ 0.27
26	553415	Adapter Plate Trunnion (SMT)	2	\$ 11.47

* Per each list price

** See pages 12-13 for Aerator Tines / Left and Right Hand Tine Gang

*** Parts for Rock Guard Kit

As viewed from above Smart-Till® Machine - ST101

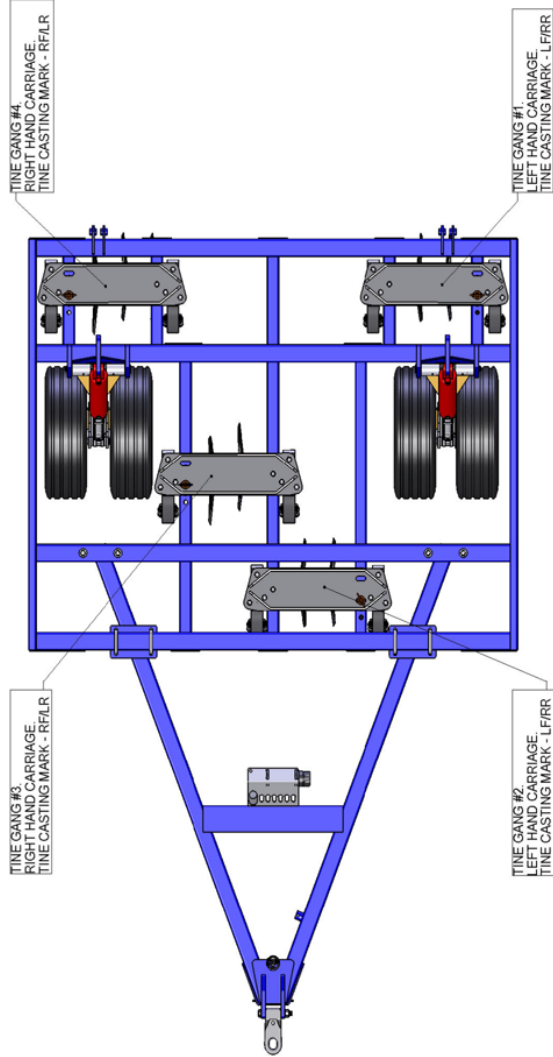

LF/R/R = PART NUMBER 231250
RF/L/R = PART NUMBER 231251

As viewed from above Smart-Till® Machine - ST151

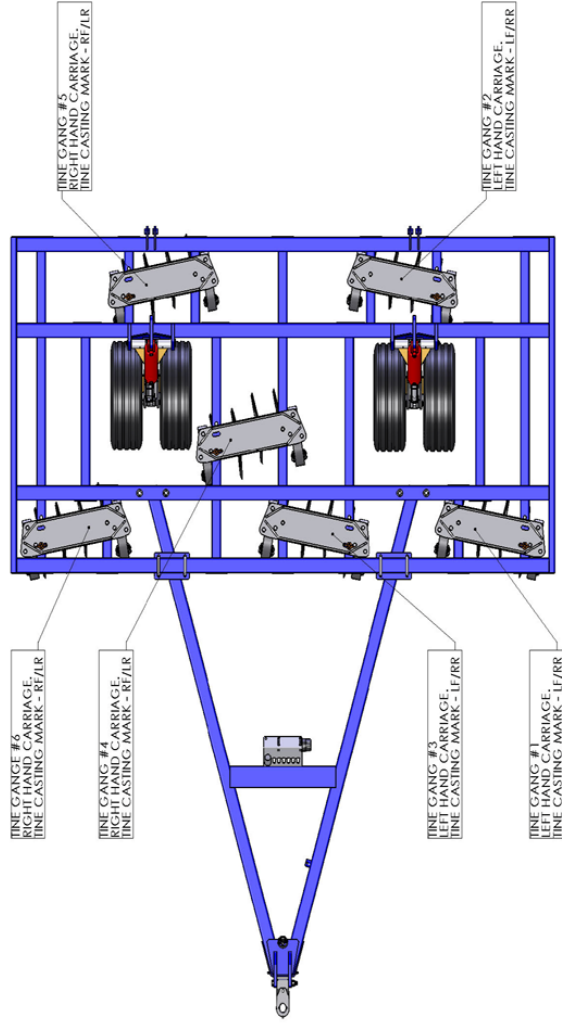

LF/R/R = PART NUMBER 231250
RF/L/R = PART NUMBER 231251

SMT101 - Part # 003110	Qty.	List Price Per Each
002959* - Left Tine Gang Kit	2	\$ 400.56
002958* - Right Tine Gang Kit	2	\$ 400.56
553389 - Trunnion Bearing	8	\$ 173.53

SMT151- Part # 003115	Qty.	List Price Per Each
002959* - Left Tine Gang Kit	3	\$ 400.56
002958* - Right Tine Gang Kit	3	\$ 400.56
553389 - Trunnion Bearing	12	\$ 173.53

*Please reference the chart for the quantities needed for each part number to replace tines or bearing on an entire Smart-Till® unit. Part numbers 002959 and 002958 includes all tines, bolts, and nuts that are needed to change tines on one left or one right gang.

As viewed from above Smart-Till® Machine - ST203

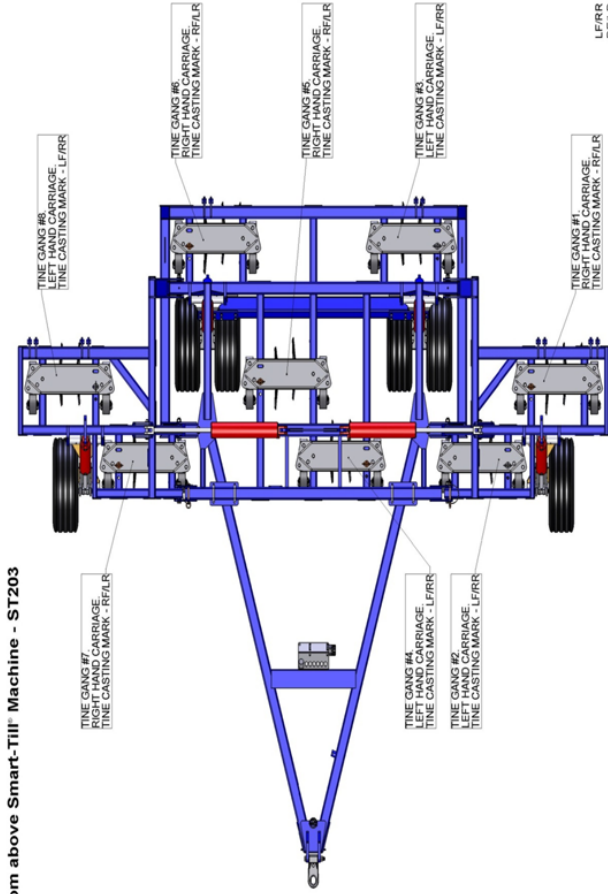

LFRR = PART NUMBER 231250
RFLR = PART NUMBER 231251

SMT203- Part # 003120	List Price	Qty.	Per Each
002959* - Left Tine Gang Kit	\$ 400.56	4	\$ 400.56
002958* - Right Tine Gang Kit	\$ 400.56	4	\$ 400.56
553389 - Trunnion Bearing	\$ 173.53	16	\$ 173.53

As viewed from above Smart-Till® Machine - ST303

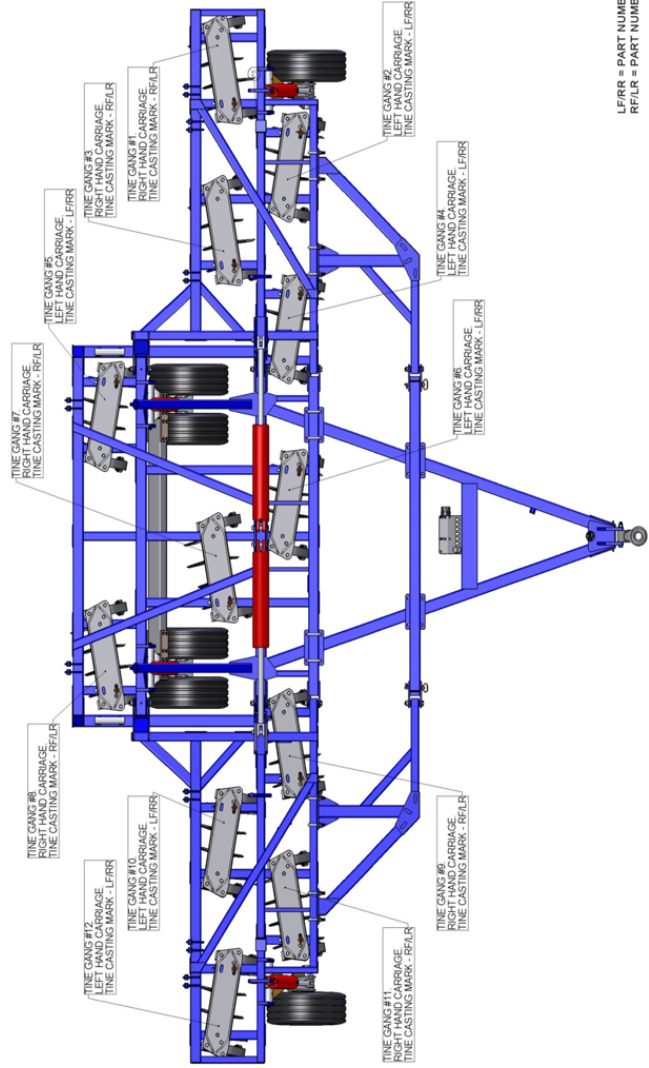

LFRR = PART NUMBER 231250
RFLR = PART NUMBER 231251

SMT303- Part # 003130	List Price	Qty.	Per Each
002959* - Left Tine Gang Kit	\$ 400.56	6	\$ 400.56
002958* - Right Tine Gang Kit	\$ 400.56	6	\$ 400.56
553389 - Trunnion Bearing	\$ 173.53	24	\$ 173.53

*Please reference the chart for the quantities needed for each part number to replace tines or bearing on an entire Smart-Till® unit. Part numbers 002959 and 002958 includes all tines, bolts, and nuts that are needed to change tines on one left or one right gang.

Smart-Till® Hardware (Not Shown)

Item No.	Part Number	Description	Jan. 2014 List Price*
H1	202936	Bolt, 5/8-11 UNC x 8" long	\$ 4.13
H2	202721	Bolt, 3/4-10 UNC x 3-3/4" long	\$ 3.73
H3	202935	Bolt, 3/4-10 UNC x 4-1/2" long	\$ 3.73
H4	202931	Bolt, 3/4-10 UNC x 6" long	\$ 5.51
H5	202929	Bolt, 3/4-10 UNC x 7-1/2" long	\$ 8.40
H6	202932	Bolt, 1-8 UNC x 8" long	\$ 11.56
H7	202937	Bolt, 1-8 UNC x 6-1/2" long	\$ 16.04
H8	202938	Bolt, 1-8 UNC x 9-1/2" long	\$ 26.18
H9	214601	Flat Washer, 3/4"	\$ 0.40
H10	214603	Flat Washer, 1"	\$ 0.36
H11	216188	Flat Washer, 1-1/4"	\$ 6.27
H12	212167	Lock Nut, 5/8-11 UNC	\$ 1.11
H13	212503	Lock Nut, 3/4-10 UNC	\$ 0.98
H14	212504	Lock Nut, 1-8 UNC	\$ 2.93
H15	216183	Pin Lock, Transport Lock	\$ 3.82
H16	216189	Hitch Pin, 0.75" diameter - 5.50" Effective Length (30' Transport Pin Wings)	\$ 24.22
H16	216184	Hitch Pin, 0.625" diameter x 5" Effective Length (20' Transport Pin Wings)	\$ 21.52
H17	216185	Pin, 1" diameter x 6" long	\$ 17.87
H18	216187	Pin, 1-1/4" diameter x 6" long	\$ 71.96
H19	216173	Retaining Ring	\$ 0.80
H20	222201	Worm Screw Clamp, 4" diameter	\$ 2.27

Smart-Till® Light Kits and Hose Kits (Not Shown)

Item No.	Part Number	Description	Jan. 2014 List Price*
—	235226	ST-101 Harness and Lights Kit	\$ 209.75
—	235225	ST-151 Harness and Lights Kit	\$ 276.31
—	235227	ST-203 Harness and Lights Kit	\$ 450.90
—	235229	ST-303 Harness and Lights Kit	\$ 592.14
—	263553	ST-101 Hose Kit (equipped with rotary harrows)	\$ 458.65
—	263555	ST-101 Hose Kit (without rotary harrows)	\$ 205.24
—	263552	ST-151 Hose Kit (equipped with rotary harrows)	\$ 482.57
—	263554	ST-151 Hose Kit (without rotary harrows)	\$ 221.16
—	263561	ST-203 Hose Kit (equipped with rotary harrows)	\$ 1,068.14
—	263563	ST-303 Hose Kit (equipped with rotary harrows)	\$ 1,253.90

* Per each list price

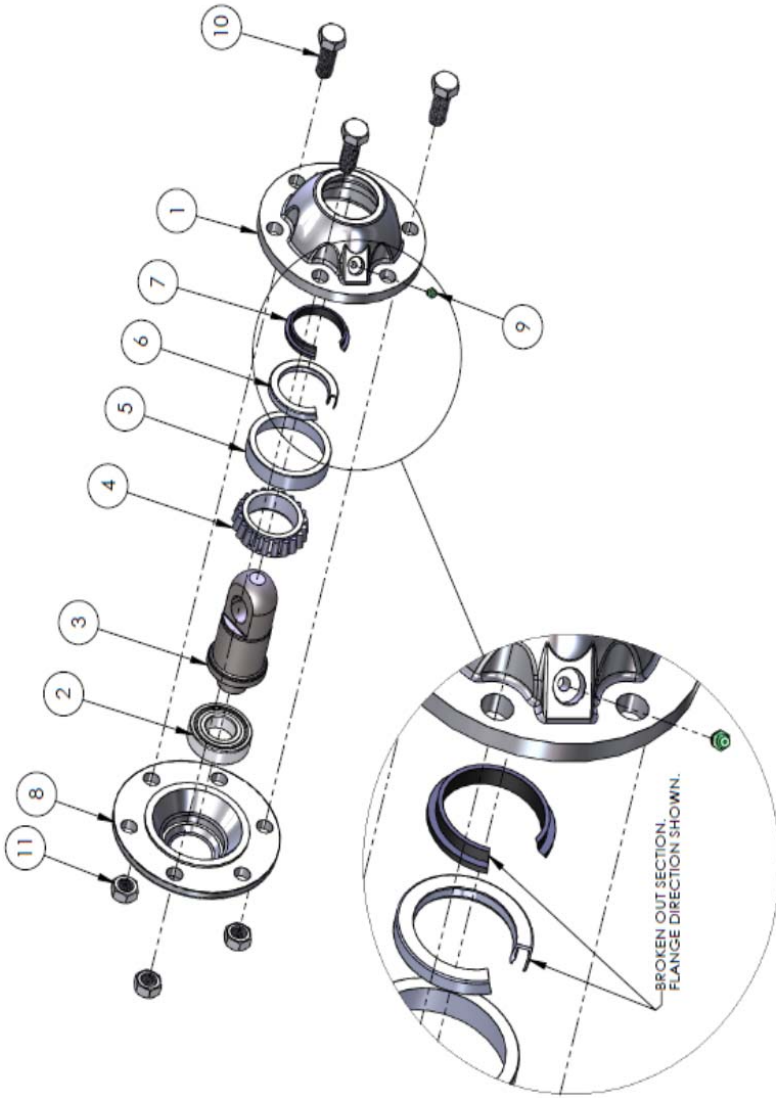

853107 - Assembly-Harrow Bearing Housing

Item No.	Part Number	Description	Qty.	Jan. 2014 List Price*
1	231279	Bearing Housing - Front	1	\$ 136.04
2	231284	Bearing	1	\$ 14.75
3	231278	Shaft	1	\$ 46.06
4	231283	Bearing - Tapered Roller	1	\$ 23.65
5	231282	Bearing - Race	1	\$ 9.61
6	231289	Seal	1	\$ 5.89
7	231290	Seal	1	\$ 12.98
8	231280	Bearing Housing - Back	1	\$ 113.92
9	226328	Grease Nipple - 1/4 UNF	1	\$ 0.36
10	202270	Bolt - Hex Head Machine Screw, 5/8-11 x 1.50"	3	\$ 0.80
11	231286	Hex Nut	3	\$ 1.02

* Per each list price

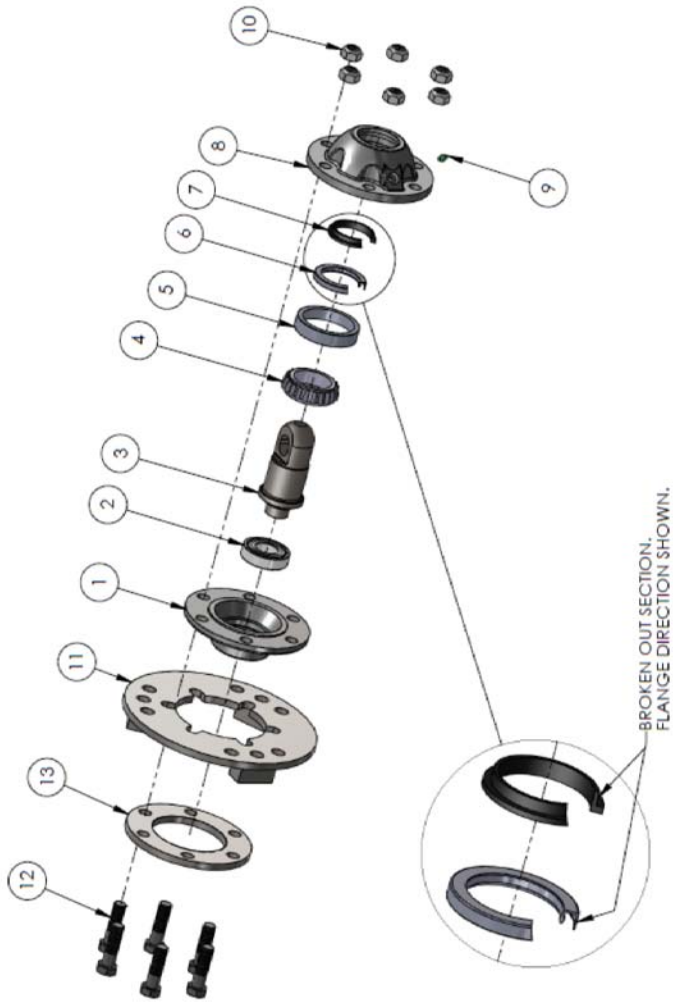

853120 - Assembly - Harrow Bearing Housing

Item No.	Part Number	Description	Qty.	Jan. 2014 List Price*
1	231280	Bearing Housing - Back	1	\$ 113.92
2	231284	Bearing	1	\$ 14.75
3	231278	Shaft	1	\$ 46.06
4	231283	Bearing - Tapered Roller	1	\$ 23.65
5	231282	Bearing - Race	1	\$ 9.61
6	231289	Seal	1	\$ 5.89
7	231290	Seal	1	\$ 12.98
8	231279	Bearing Housing Front	1	\$ 136.04
9	226328	Grease Nipple - 1/4 UNF	1	\$ 0.36
10	231286	Hex Nut	6	\$ 1.02
11	853119	Weldment-Harrow Hub Plate	1	\$ 61.17
12	202085	HHCS .625-11 X 2.25	6	\$ 1.33
13	553319	Plate - Harrow Hub Back	1	\$ 10.86

* Per each list price

SMT Decals

SMT Decals		
Part No.	Description	Qty Required
275290	Harrow Adjustment	2, 3, 5, or 7 ¹
275291	Left Gang Adjustment	2, 3, 4, or 6 ¹
275292	Right Gang Adjustment	2, 3, 4, or 6 ¹
275273	Safety Kit	1
275300	SMT Tongue	2
275301	SMT101 Frame	2
275302	SMT151 Frame	2
275303	SMT203 Frame	2
275304	SMT303 Frame	2

¹ Quantity varies by implement model/size.

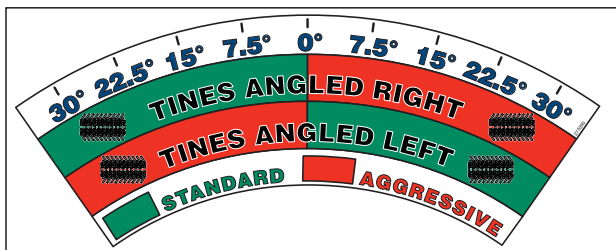

275290 Harrow Adjustment

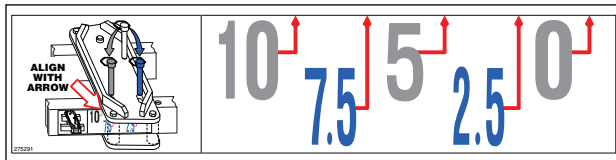

275291 Left Gang Adjustment

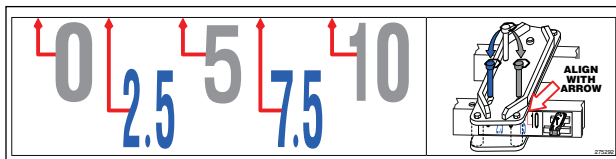

275292 Right Gang Adjustment



275300 SMT Tongue



275301 SMT101 Frame



275302 SMT151 Frame



275303 SMT203 Frame



275304 SMT303 Frame



Hose Holder Decal - Included in 275273

Warning Decals

Warning Decals		
Part No.	Description	Qty Required
ST-001	Read the Manual	1
ST-002	High-Pressure Fluid	1
ST-003	Electrocution Hazard	1
ST-004	Falling Wing Hazard	1
ST-005	Puncture Hazard	1
ST-056	Negative Tongue Weight	1
ST-057	Shut Off Machinery	1
ST-058	Check Hardware Torque	1
ST-059	Pinch Point Warning (large)	2 or 4 ¹
ST-059a	Pinch Point Warning (small)	4, 6, 8, or 12 ¹

¹ Quantity varies by implement model/size.

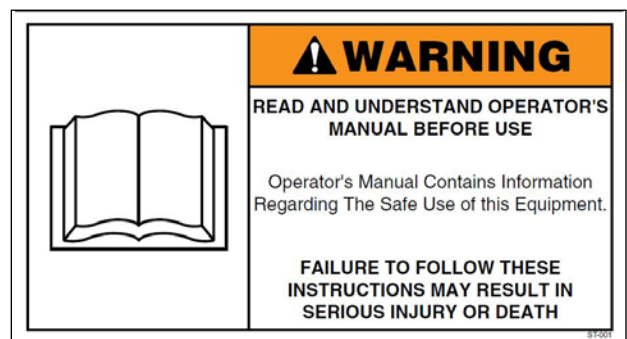

ST-001 Read the Manual

Warning Decals (continued)

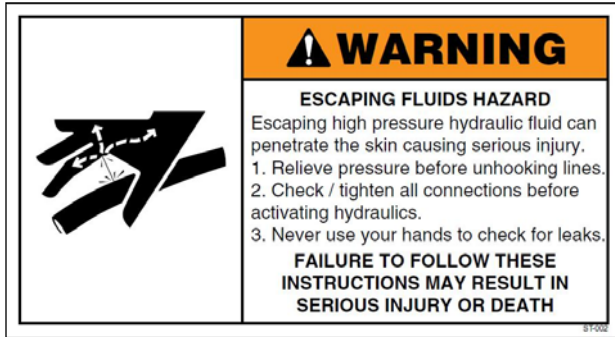

ST-002 High-Pressure Fluid

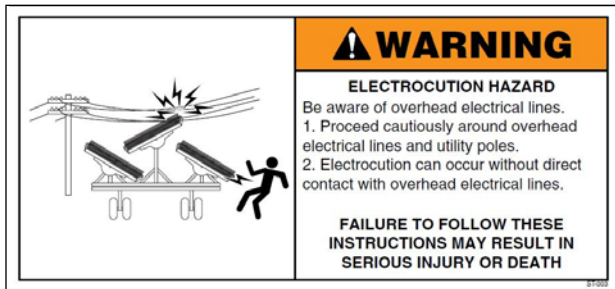

ST-003 Electrocutation Hazard

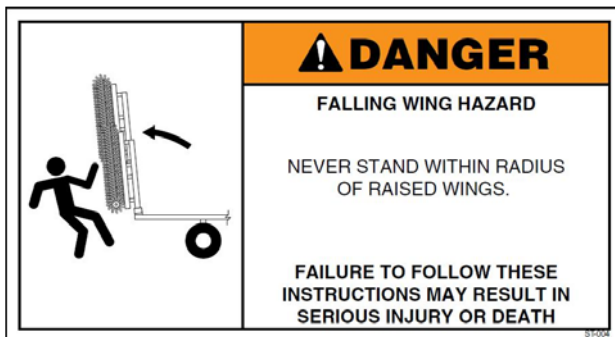

ST-004 Falling Wing Hazard



ST-005 Puncture Hazard

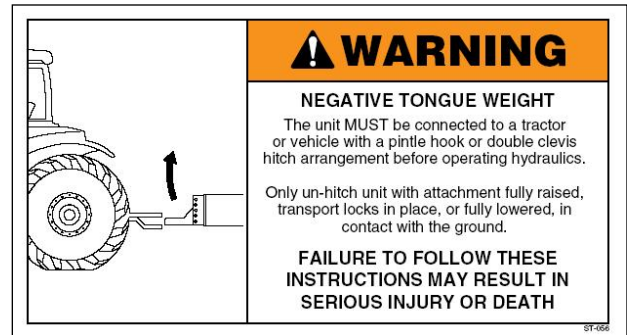

ST-056 Negative Tongue Weight

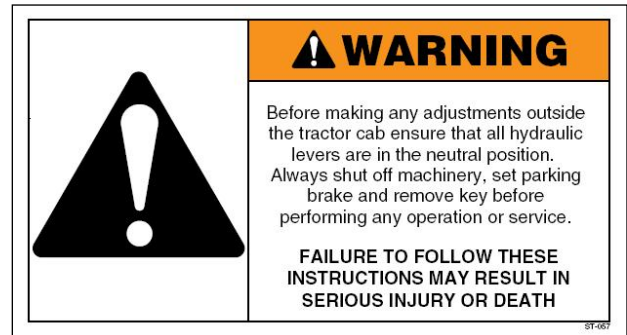

ST-057 Shut Off Machinery



ST-058 Check Hardware Torque



ST-059a Pinch Point Warning (small)



ST-059 Pinch Point Warning (large)



HCC, inc.[®]

1501 1st Avenue
Mendota, IL 61342
Phone: (815) 539-9371
www.smart-till.com

C-1184 January 2014